

The display consists of a 9" amber monitor. Input is 75 Ohm composite video into pin 8 of the edge connector at the back of the monitor. Power (+12v, 1.2 Amp.) is supplied to pin 7 with pins 1 and 10 being system ground. Connections and adjustments are shown in Figure 1.

GENERAL DISPLAY

SPECIFICATIONS
 HORIZONTAL FREQUENCY
 VERTICAL FREQUENCY
 SIGNAL POLARITY
 VIDEO
 TERMINATION IMPEDANCE
 RESOLUTION
 BANDWIDTH
 LINEARITY

AND

CHARACTERISTICS
 15.75 kHz
 60 Hz
 POSITIVE - THE WHITES ARE HIGH
 COMPOSITE - AMPLITUDE 2.5 TO 5 VPP
 75 Ohms
 900 TV LINES, CENTER
 DC TO 18 mHz AT -3dB
 CHARACTERS ARE TO BE WITHIN $\pm 10\%$ OF ADJACENT CHARACTERS AND WITHIN $\pm 10\%$ OF CHARACTER HEIGHT
 GEOMETRIC DISTORTION TO BE WITHIN 1 -1/2% OF EIA

GEOMETRY

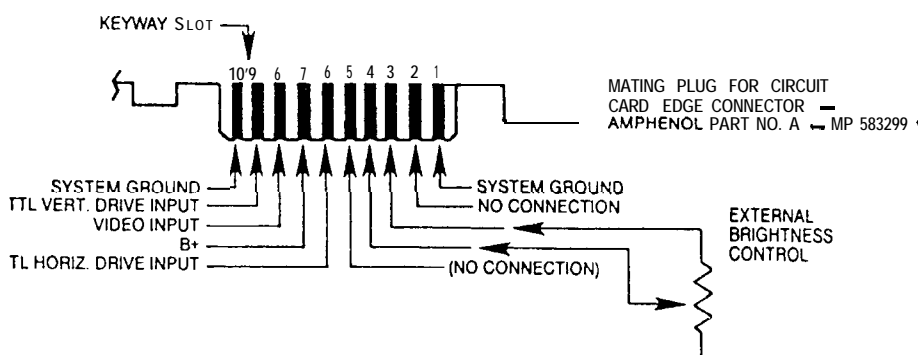
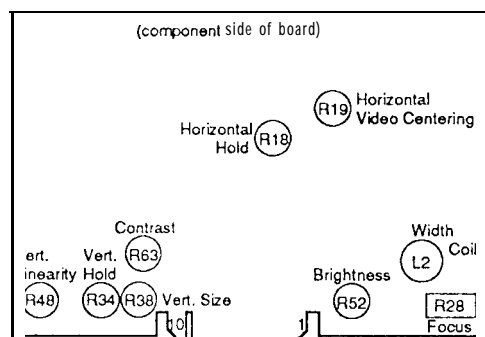

Fig. 1 Monitor circuit card edge connector--component side view and adjustments.

Although the monitor alignment adjustments are preset at the factory, alignment procedure is given below in case adjustments would be necessary.

1. Check size--horizontal and vertical.
 - A. If the horizontal size requires readjustment, use width coil (L2) to set size to +1/4 inch of spec.
 - B. If vertical size requires readjustment, use height control (R38) to set size to +1/4 inch of spec. Readjustment of linearity control (R48) may be necessary.
2. Check brightness adjustment - increase remote brightness control to maximum. Raster lines should be just barely visible.
 - A. Increase master brightness control (R52) until raster lines are visible.
 - B. Reset remote brightness to normal viewing level.
3. Check horizontal centering - increase remote brightness control until raster lines are just visible. No more than one (1) character width difference should be measured when comparing the right side spacing, between the raster edge and the video, to the left side spacing.
 - A. If necessary, adjust the horizontal delay control (R19) only for minor correction.
 - B. If considerable adjustment is required, the following steps should be taken.
 - 1) Disable horizontal sync. input.
 - 2) Adjust horizontal hold control (R18) to achieve a single vertical band of the horizontal blanking interval floating through the video presented.
 - 3) Enable the horizontal sync. input.
 - 4) Adjust horizontal delay control (R19) to center the video in raster.
 - C. Reset the remote brightness control for normal level.
4. Check focus.
 - A. If necessary, adjust the focus control (R28) to obtain the best overall focus. Center focus will be compromised in order to gain better corner focus.
5. Check geometry - rectangular presentation of video display.
 - A. If correction is required, adjust the magnets on the yoke ring as required.

The display monitors are supplied with yokes on which a special retainer has been designed to accommodate adjustable magnets. The tabs on this retainer hold the magnets in place and keep them from vibrating loose in transit. These magnets can be rotated in either direction until satisfactory geometry has been achieved.

NOTE!

The geometry has been adjusted at the factory prior to shipment. If, however, adjustments are to be made on the yoke, the directions on this page should prove helpful.

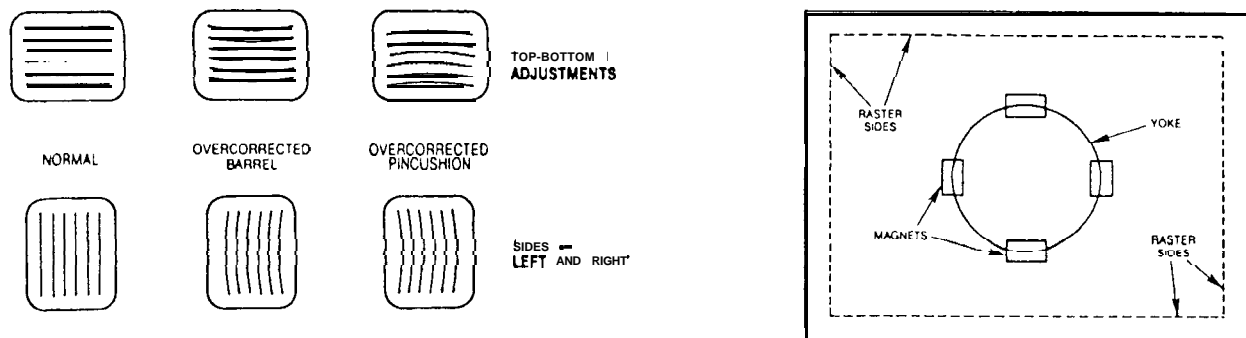

Fig. 2 Geometry adjustments.

SAFETY NOTE!

All CRT's maintain a voltage charge at the anode, even when inoperative. Therefore, when a CRT is to be replaced, always discharge the picture tube anode to ground using an insulated wire or screwdriver. Safety goggles usage is recommended by CRT manufacturers.

TROUBLE SHOOTING

1. NO RASTER

- A. Check to see if high Voltage exists at second anode by marginal arcing to chassis (signal should be disconnected) or check with high Voltage meter (approx. 12kV).
- B. Check to see if G2 Voltage is 600 Volts or more.
- C. Check grid lead for a negative to positive Voltage swing by varying the brightness pot. -100 to +30 Vdc should be present at the green lead (Grid 1).
- D. Check positive and negative Voltages derived from flyback.

2. NO VIDEO

- A. Make sure that the raster is visible and that the video lead is not broken.
- B. Check the Voltage on the collector of Q4. It should be approximately 50 Vdc.
- C. Check the bias Voltage at Q4. It should be approximately 6 Vdc. If Q4 defective, check D12.

3. NO VERTICAL SWEEP

- A. Check for B+ (12V) to pins #2 & 5 of ICU1.
- B. Make sure that the yoke and leads are hooked up properly.
- C. Check the Voltage on pin #4 of ICU1. It should be 6 to 7 Volts. If the Voltage is 10, check C56.
- D. Shunt C29 with new capacitors.

4. HIGH CURRENT FROM POWER SUPPLY

- A. Unsolder one end of C14. If high current still exists, the horizontal output stage (Q2) is at fault. The normal current is from .7 to 1 .1 Amps.
- B. Check for shorted Q2, D3, D4 and D5. Defective flyback is the least probability. If disconnecting C14 does not correct high current, ICU2 may be shorted.

5. POOR LINEARITY

- A. Vertical - check C56.

6. EXCESSIVE BRIGHT

- A. Check negative Voltage on D3. Possible open C21.
- B. Check B+ Voltage at the collector of video (Q4). Output should be approximately 40 Vdc.

7. NO SYNC

- A. Check pin #8 of ICU2 for sync pulses. Also, check for feed-back pulses to pin #6 of ICU2 from the horizontal out section. If both pulses are present, replace the chip. If composite signal is used and present to pins #8 & 9 of ICU2, pin #10 should have vertical sync as output.

8. NO HORIZONTAL DEFLECTION (line up and down)

- A. Check the leads on the yoke (C19).

9. NO VERTICAL DEFLECTION (line right and left)

- A. Check for open yoke.
- B. Check the leads on the yoke (blue and yellow).
- C. Check for open D7 or C29.

10. NO HORIZONTAL DEFLECTION, NO HIGH VOLTAGE

- A. Check pin #2 of ICU2. If Voltage is 4.5 Vdc, the chip is OK. If it is 11 Vdc, replace the chip.
- B. Check pin #1 of ICU2. If Voltage is not 10 Vdc, look for open R21, 15 Ohms.
- C. Check for pulses on pin #2 of ICU2, If pulses are present, the chip is OK.
- D. The base of Q2 should have a square waveform if not open C1 4, or shorted Q2. If pulses are not present on pin #2 of ICU2, C1 1 may be open.

REPLACEMENT PARTS LIST

| REF. # | QTY. | DESCRIPTION | REF. # | QTY. | DESCRIPTION |
|-------------------------|------|--------------------|----------------------------|------|---------------------|
| R16 | 1 | 2.2 meg. 1/4 W 5 % | Capacitor, Electrolytic | | |
| R42 (Yoke) | 1 | 180 Ohm 1/2 W 5 % | C9 | 1 | 1 uF 50 v |
| R27 | 1 | 2 meg. 1/2 W 5 % | C14 | 1 | 4.7 uF 35 v |
| Resistor., MF | | | C10., c56 | 2 | 22 uF 35 v |
| R15 | 1 | 9.09 k 1/4 W 1 % | C38 | 1 | 33 uF 63 V |
| R22 | 1 | 33 k 1/4 W 1 % | C31, C33, C46 | | |
| R17 | 1 | 47.3 k 1/4 w 1 % | C47, C48 | 5 | 100 uF 25 V |
| R12 | 1 | 220 k 1/4 w 1 % | c39 | 1 | 220 uF 16 V |
| Resistor, CC | | | C40 | 1 | 470 uF 16V |
| S2 | 1 | 220 Ohm 1/2 W 10 % | c29 | 1 | 2200 uF 10 V |
| S3, s4 | 2 | 1 k 1/2 W 5 % | C19 | 1 | 12uF 25 V Bipolar |
| Resistor, Power MO | | | C18 | 1 | 330 uF 16V LESR |
| R90 | 1 | 1 k 3 W 5 % | Capacitor, Monolytic | | |
| Pot/Carbon | | | C11 | 1 | .0047 uF 100 V NPO |
| R63 | 1 | 500 Ohm | C8, C30, C51 | 3 | .022 uF 50 V 10 X7R |
| R34 | 1 | 100 k | c4 | 1 | .47 uF 50 v 10 |
| R48 | 1 | 200 k | c3, c7 | 2 | .22 uF 50 v 10 |
| R38 | 1 | 500 k | C5, C6, C12, C27, C41, C45 | 6 | .1 uF 50v 10 |
| Pot/Cermet | | | Transformer, High Voltage | | |
| R18 | 1 | 30 k | T1 | 1 | Flyback |
| R19 | 1 | 200 k | Diode | | |
| R52 | 1 | 250 k | D1, D6, D12 | 3 | 1N4148 |
| R28 | 1 | 2 meg. | Diode, Power | | |
| Yoke (2651D) | | | D5 | 1 | GI I-1200 |
| Coil | | | D14 | 1 | MR818 |
| L3 | | 4.7 uF Peaking | D7 | 1 | 1N4004 |
| L1 | 11 | Linearity | D2, D3, D4 | 3 | 1 N4936 |
| L2 | | Width | Diode, Zener | | |
| Capacitor, Ceramic Disc | | | D8, D9 | 2 | 1N4733A |
| c23 | 1 | .01 F 1 kV Z5U | D10, D16 (bottom) | | |
| c22, c37 | 2 | .01 F 100 V Z5U | R18 to R1) | 2 | 1 N5234 B |
| C42 | 1 | 120 pF 100 V NPO | Transistor, SS | | |
| C16 | 1 | 33 pF 100 V NPO | Q3, Q5 | 2 | 2N3904 |
| C49, C57, C52 | 3 | .001 F 1 kV Z5U | Q1, Q6, Q7 | 3 | 2N3906 |
| C21, C36 | 2 | .01 uF 500 v | Transistor, Power | | |
| C28 | 1 | 68 pF 100 V 5 | Q2 | 1 | BU806 |
| Capacitor, Mylar | | | Q4 | 1 | MPSU07 |
| C1, C34, C35, C26 | 4 | .1 uF 100 V 5 | Integrated Circuit | | |
| C17 | 1 | .033 uF 400 V | U1 | 1 | TDA1170S |
| | | | u2 | 1 | TDA1180 |
| | | | Cathode Ray Tube | 1 | CE663W9H194GR |

